



[www.greenevo.com.my](http://www.greenevo.com.my)

Greenevo Synergy® Sdn Bhd 201201015176  
Greenevo Synergy® Industries Sdn Bhd 201501036724  
No 12A, Jalan 2,  
Kws Perindustrian Lekas 18,  
43500 Semenyih,  
Selangor, Malaysia.

T (603) 8726 9999  
F (603) 8726 9988  
E [gvgroup@greenevo.com.my](mailto:gvgroup@greenevo.com.my)

DISTRIBUTOR PARTNER



70Q20860

Your solutions partner



## about us

Greenevo Synergy® Sdn Bhd was incorporated in 2008 under the Malaysia Companies Act 1965. We are specialized in providing customization solutions, technical consultation and supplying all kinds of industrial products including adhesive tape, release liner, foam, thermal management products, parts and components. Our products, parts and components are tailored for market in home appliances, office automation, corrugated, solar and etc.

We are committed to providing customers with the beyond-expectation service and quality products at the best cost efficiency. We are supported by a team of highly-trained professional expert team which specifies to cater to our customers' various needs and requirements.

We possess a strong technical force and strive to provide our distinguished clients with not only premium quality products, competitive pricing, swift delivery but also our personal attention to our client's requirements and deliver beyond expectation value-added services.

### Mission

Deliver beyond expectation with our services, products, technical expertise at the best quality and competitive price.

### Vision

To be one of the leading industrial material solution providers in Malaysia.



Greenevo®,  
your preferred  
solution partner

Business coverage region

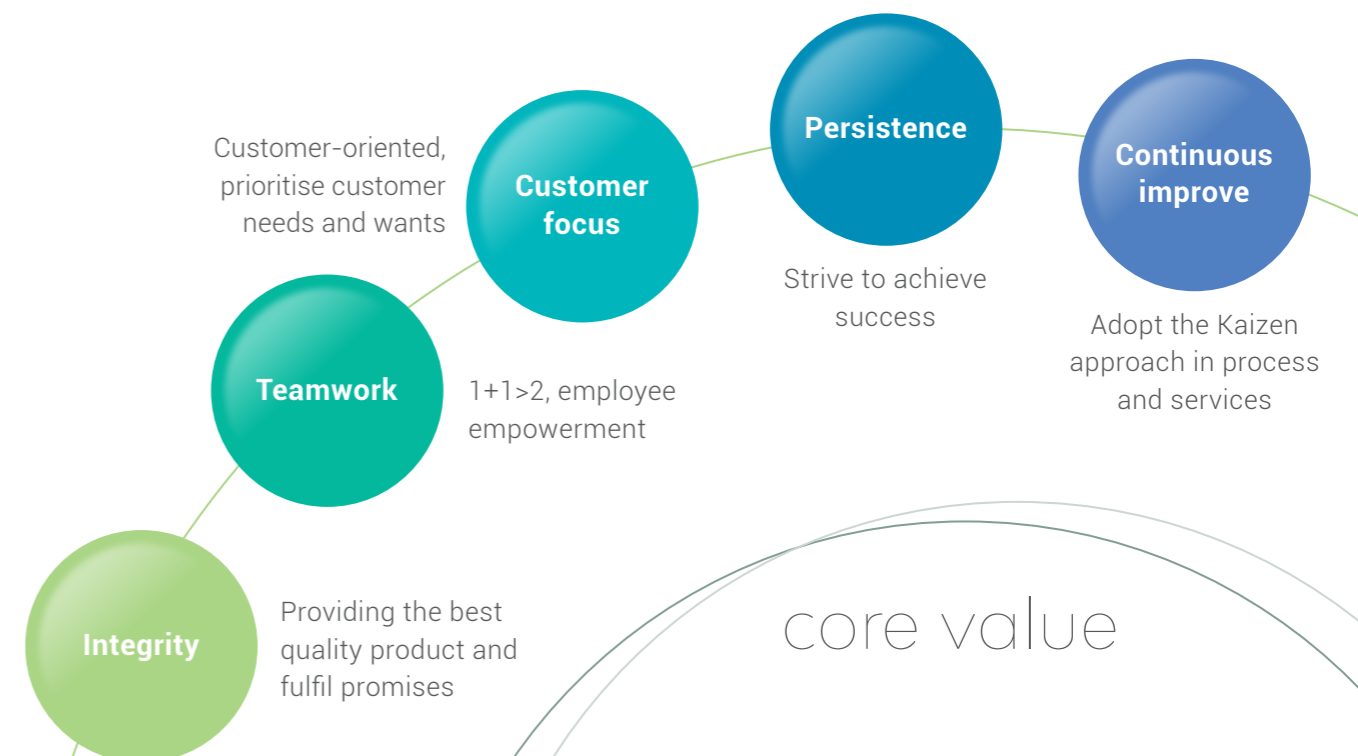

core value

## our team

We are supported by the backbone of a team of highly trained specialists and bring over a decade of extensive experience with strong business acumen and close collaboration with the industry leaders to enhance our commitment and capability to deliver your satisfaction.



### We are approachable

Always putting our customers and our own people first. We listen and work shoulder to shoulder with our customers in a supportive and collaborative way. We understand their needs better than anyone in the industry.



### We are reliable

Delivering a comprehensive assortment built on quality and expertise, through our German heritage, in-depth market knowledge and application know-how. This allows us to confidently provide the right products for the right solutions.



### We are responsive

It shows that we are agile and work seamlessly, internally with our employees and externally with our customers. We provide value-adding solutions and quick, positive responses towards their needs.



# our services

## Best R&D approach

R&D is the heartbeat of Greenevo®. We have a state-of-the-art in house R&D and laboratory setup to continuously innovate our products to cater to our customers' requirements. We always strive to provide tailor-made solutions to our customers in an agile and quick manner.

## Ensuring Peace of Mind

Quality is always our top priority thus we are consistent in maintaining the best product and machine capability. Our best-in-class experts partner closely with your team to provide you with a hassle-free and personalized experience.

# industry



## Full-scale industrial solutions

We are available to deliver a wide range of product solutions to your doorstep. We have a series of best-in-class machines such as slices, rewinding, sheet cutter, lamination and rewind slit. Our products include adhesive tape, release liner, foam, thermal management products, parts and components.

## Best people in the team

We are supported by a team of highly qualified and experienced technical and sales force. They are the best people to count on for business acumen and technical know how.

## Combination of speed and price

We win over our customers by providing price competitiveness. We understand our customers have a tight deadline to meet their customers' need. Thus, we deliver our solutions in a speedy manner to avoid unwanted situations for our customers.

# market segment



**Solar**  
Cable & cell fixation,  
frame mounting, high  
temperature masking,  
PTFE belt



**Premium box packaging**  
Carton sealing, frozen  
food boxes, knifeless box  
opening, palletizing



**Automotive**  
Wire harnessing, high  
temperature paper  
masking, PVC fine line

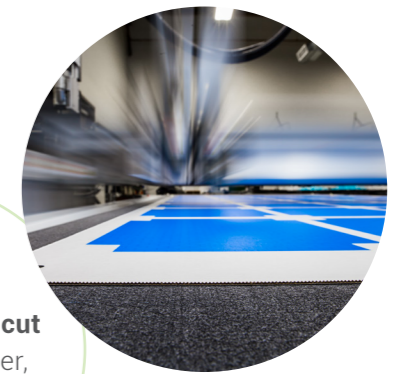

**Converting & die cut**  
Adhesive tape, liner,  
foam, protection tape



**Personal hygiene**  
Diaper and sanitary.  
Splicing tape with sensor  
detection feature, PTFE  
skived tape, anti-stick  
roller wrapping



**Home appliances**  
Vacuum,  
air conditioner

**Web processing label stock**  
High speed auto splicing,  
high temperature splicing,  
roller wrapping



**General industry**  
Masking, Mounting,  
Protection, steel coil  
end tapping, structural  
bonding, ducting  
repairing, reflector



**ID & security**  
Chip bonding, card  
attachment tape,  
temper evidence



**Office Automation**  
Copier and printer  
categories



**Special masking**  
Tape for curves, tape for  
indoor and outdoor  
painting and plastering,  
flexible fleece tape, wall  
and ceiling joint tape

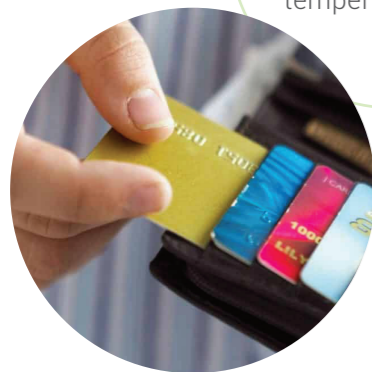

**Corrugated & packaging**  
Splicing, box closing,  
tear tape opening,  
plate mounting tape,  
polyester film

# product categories

## double sided tape

Nonwoven, Filmic, PE/PU Foam & Acrylic Foam

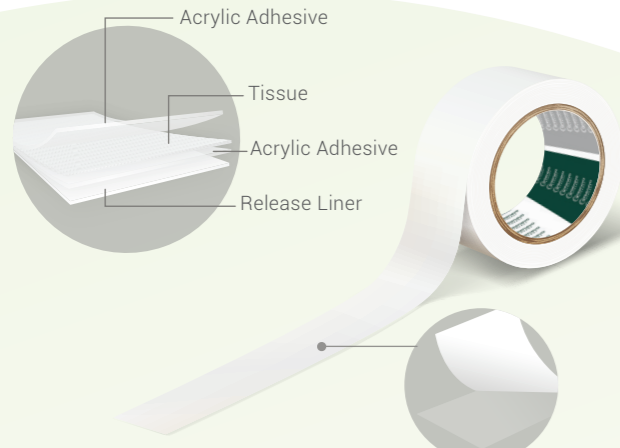

**Nonwoven**  
Double Sided Non-woven Tape

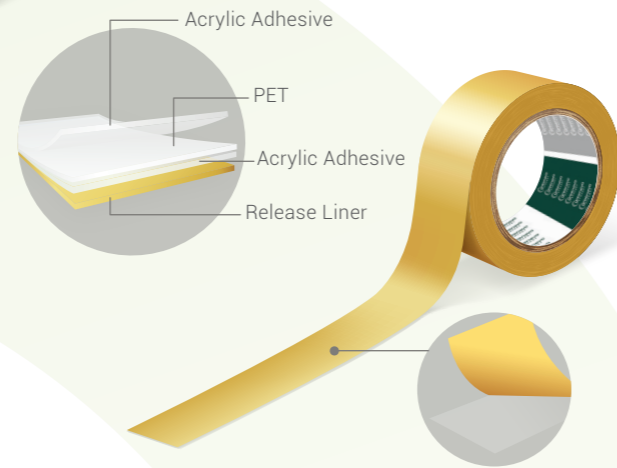

**Filmic**  
Double Sided PET Tape

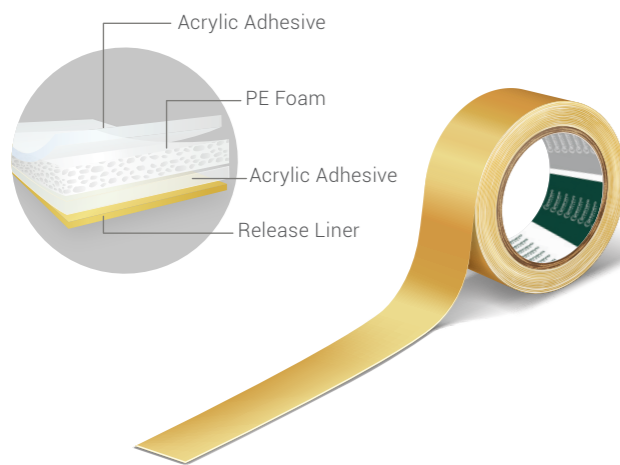

**PE/PU Foam**  
Double Sided PE Foam Tape

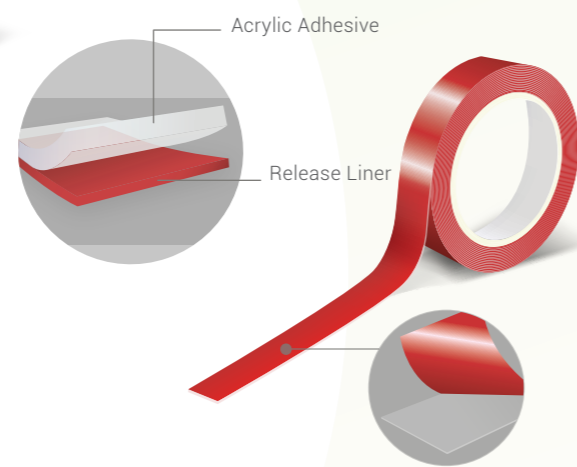

**Acrylic Foam**  
Double Sided Acrylic Tape

## single sided tape

Holding Tape, Filament Tape & High Temperature



**Holding Tape**

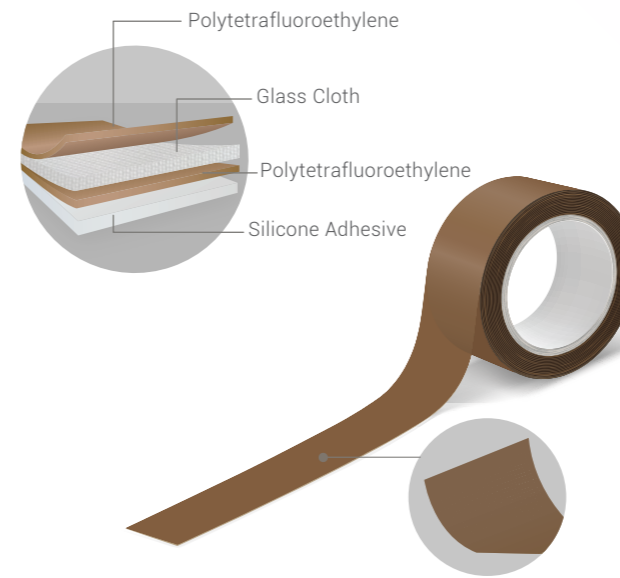

**High Temperature (PTFE)**  
PTFE Tape

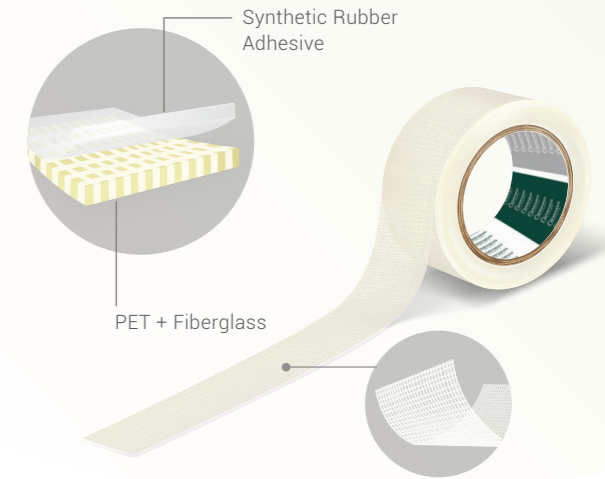

**Filament Tape**

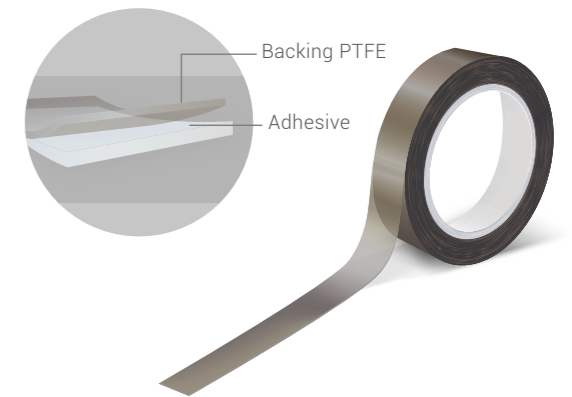

**High Temperature (PTFE)**  
PTFE Film Tape

# single sided tape

Holding Tape, Filament Tape & High Temperature

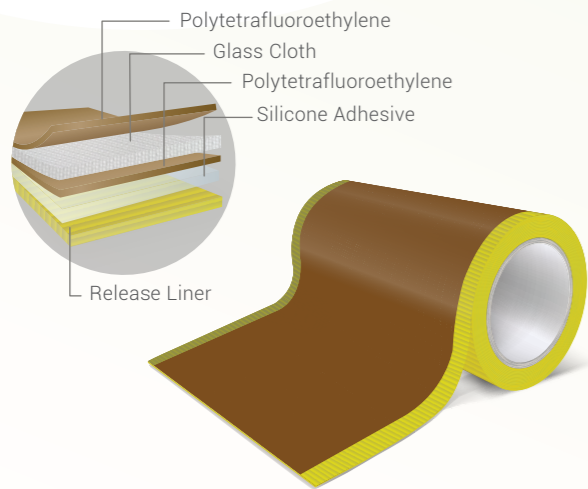

**High Temperature (PTFE)**  
PTFE Cloth with Liner

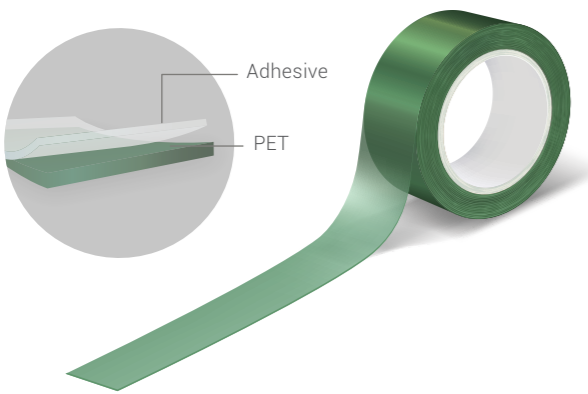
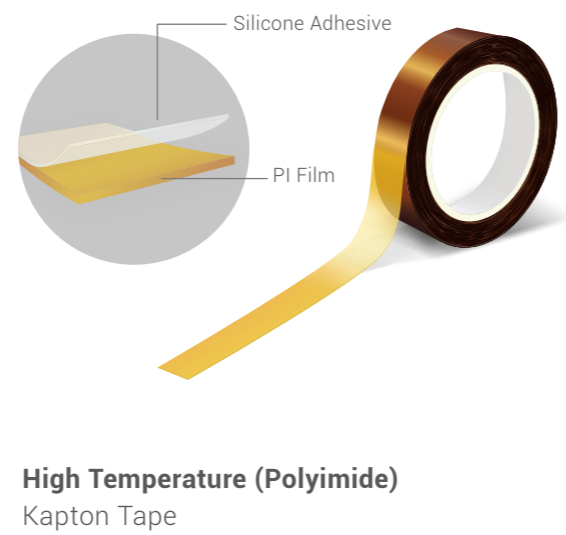

**High Temperature (Polyester)**  
Single Sided Silicone Tape

# release liner

Silicone Release Liner (Film/Paper) & Fluorine Liner (Film)

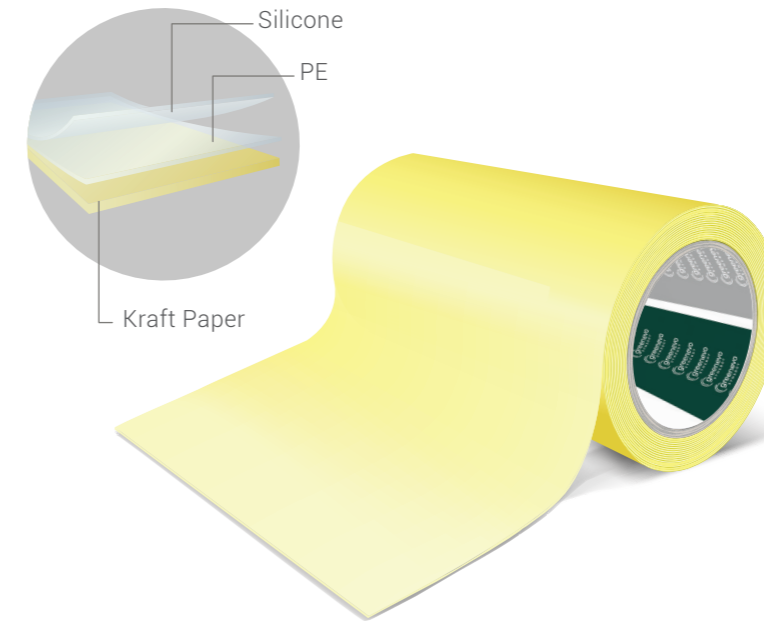

**Silicone Release Liner (Film/Paper)**  
Single Sided PE Coated Yellow Craft Paper Liner

**Fluorine Liner (Film)**  
Fluorine Release Liner

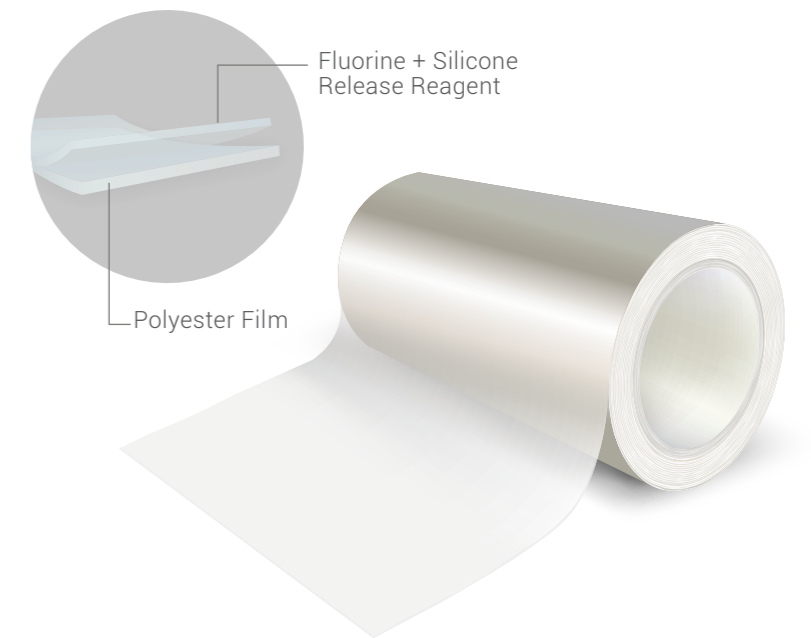

thermal pad

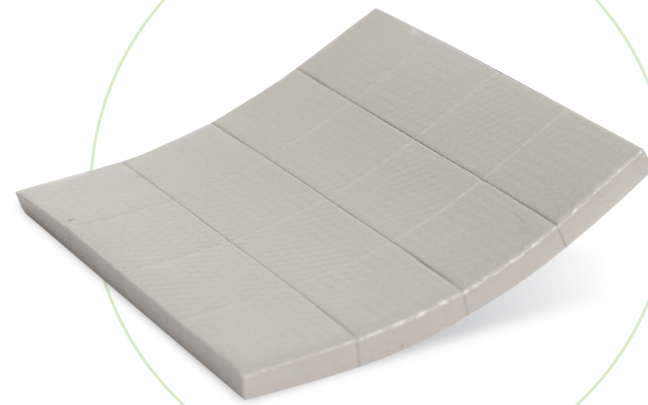

polyester film

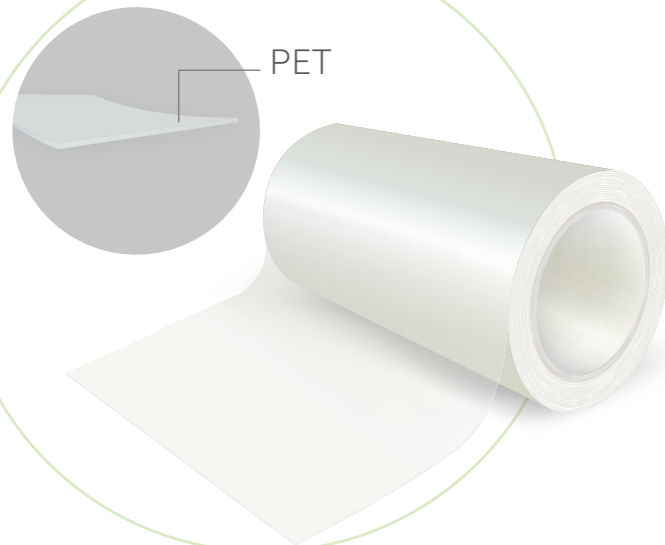

foam  
PU/Silicone/EDPM

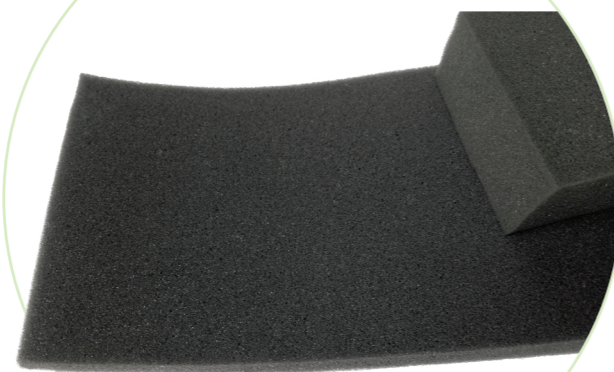

converting  
Sheet Cut/Die Cut/Lamination/Slitting

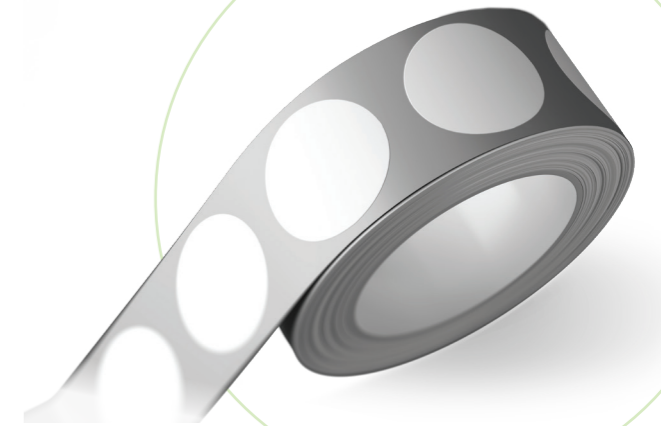

Auto Dispenser

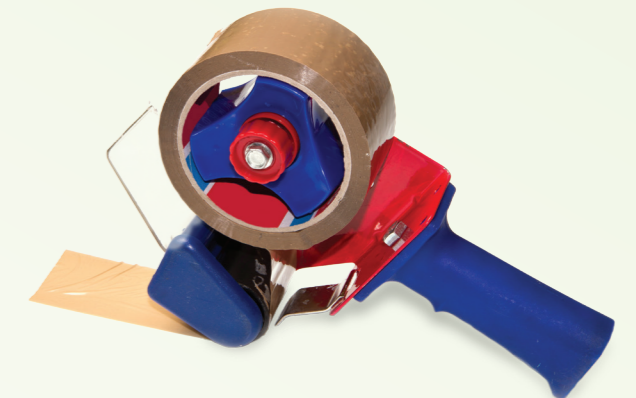

Dispenser

tools and  
accessories